



x2



x2



x2



x2



x1

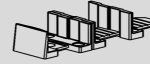

x2



x1



x1

100lb

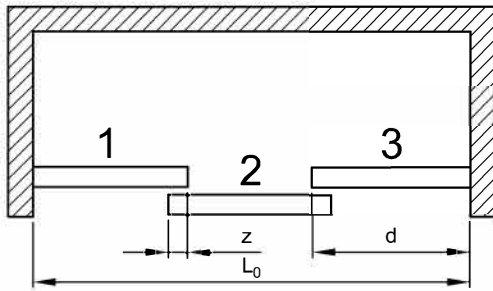

$$d = (L_0 + 2z) / 3$$

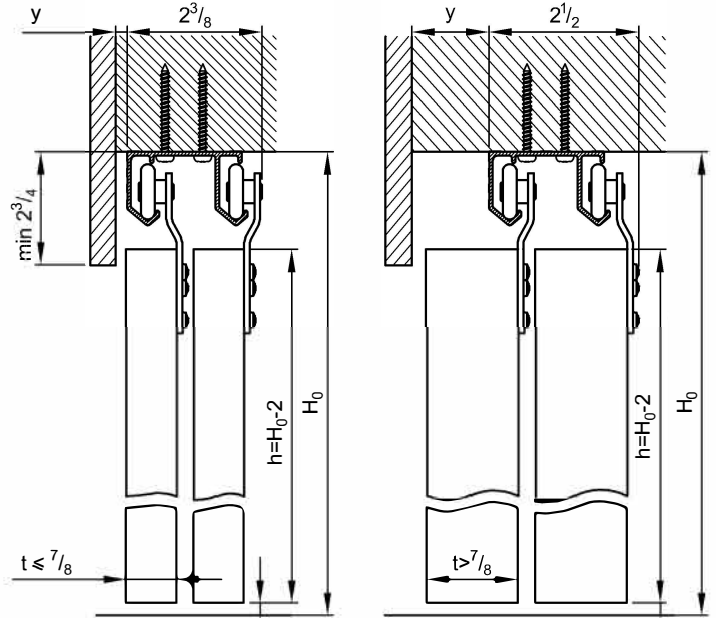

t [in]	5/8	11/16	3/4	7/8
y [in]	0	1/16	3/16	3/16 - 7/16

t [in]	> 7/8
y [in]	t - 3/8

3/16 - 7/16

1

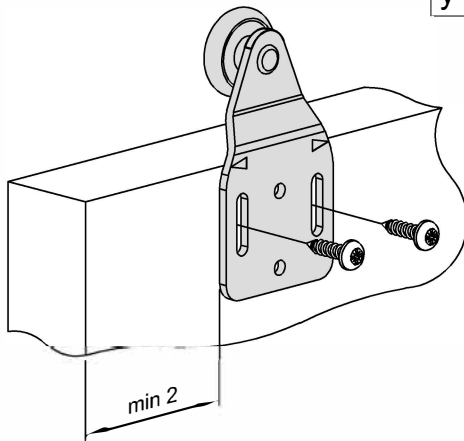

2

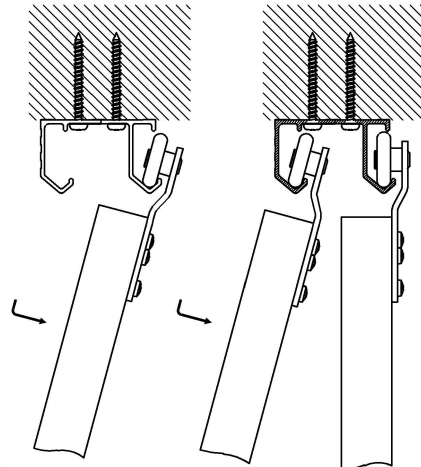

3

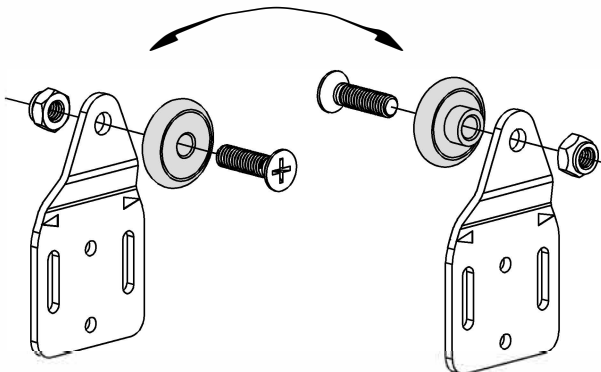

4

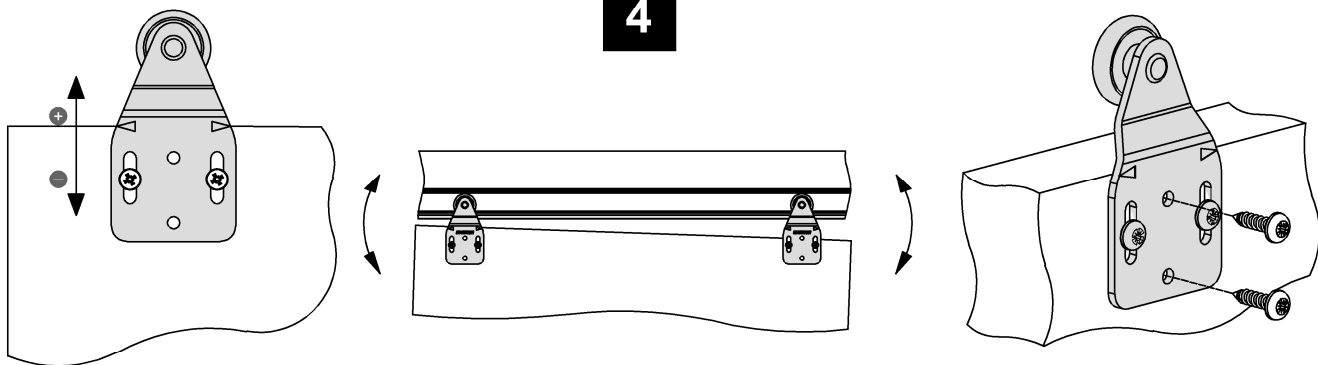

5

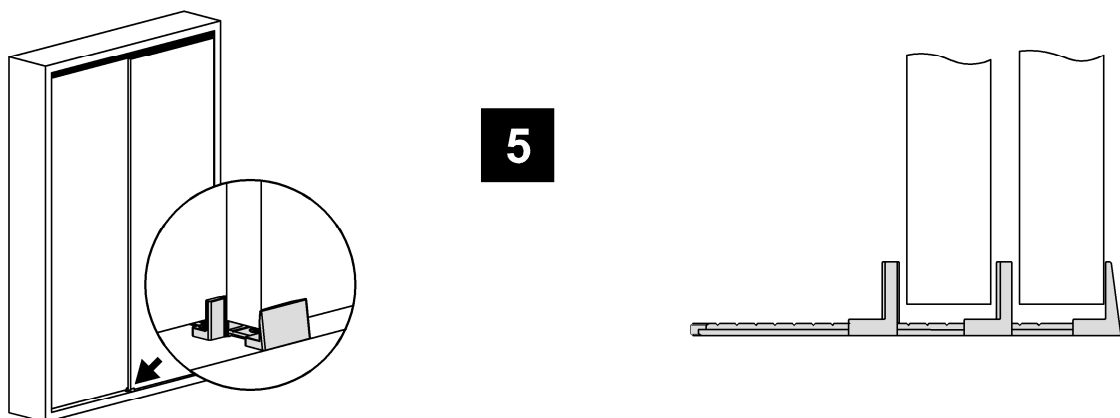

6

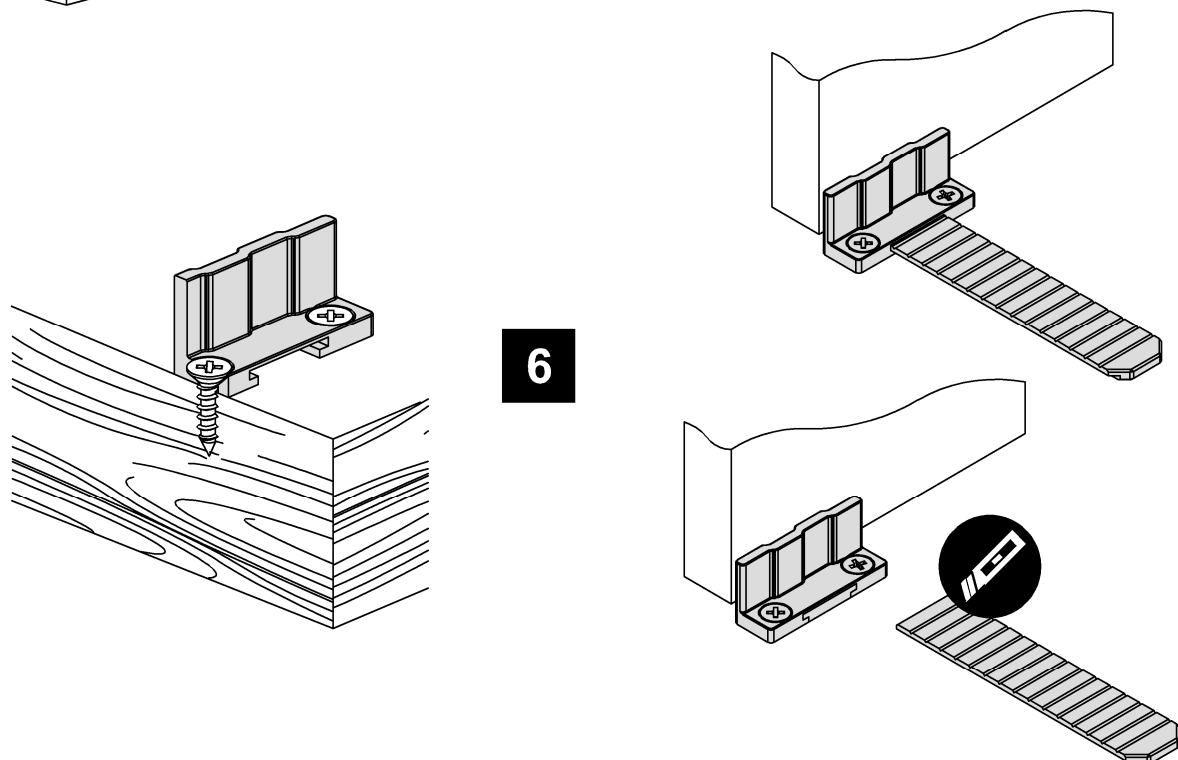

7

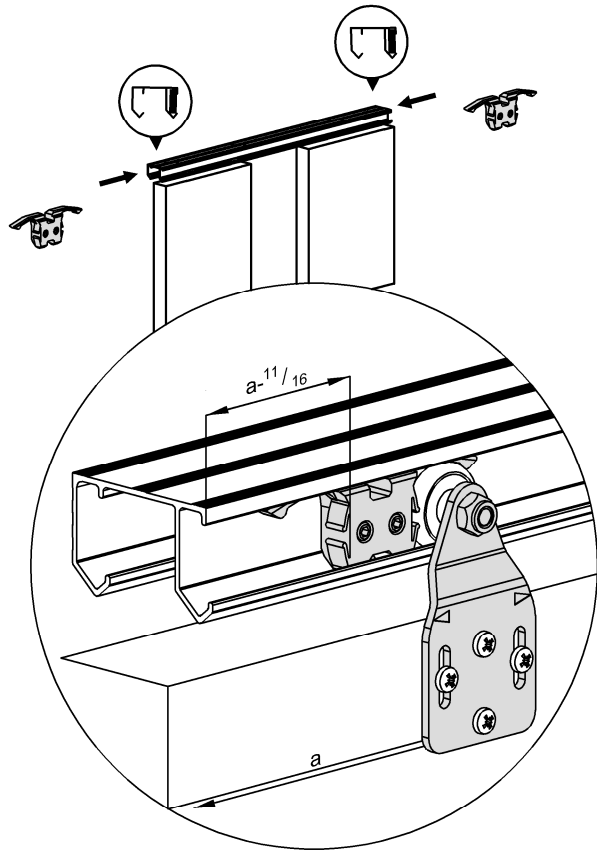
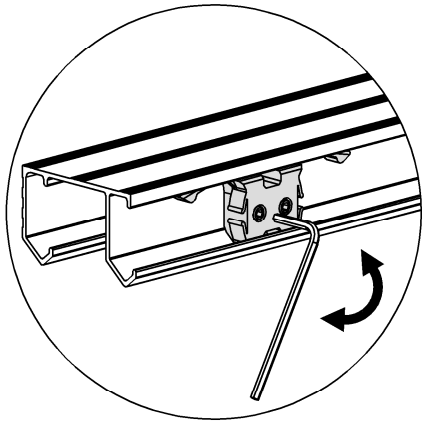

8

